



## KINGS REGIONAL SERVICE COMMISSION

27 Winter Street, Unit 1, Sussex NB E4E 2H9

email: info@KingsRSC.ca www.KingsRSC.ca

Telephone: (506) 432-7530

Mon to Fri 8am to 4pm

Permit Number

For Office Use Only

Fee

Receipt Number

Date Issued

# BUILDING FORM

### SECTION A: OWNER'S INFORMATION

Name	Family Name	Email	Home Phone
Address	Community	Province	Postal Code
			Work Phone

### SECTION B: PROPERTY INFORMATION

Address of Proposed Project	Community of Proposed Project	Municipality of Proposed Project	PID
<b>A</b> Frontage (m)	<b>B</b> Depth (m)	Area (m2)	Zoning

### SECTION C: CONSTRUCTION INFORMATION

Contractor's Name	Phone	Type of Activity	
Electrician's Name	Phone	Type of Building	
Plumber's Name	Phone	Landuse	
<b>C</b> Front Yard	<b>D</b> Side Yard (Left)	<b>E</b> Side Yard (Right)	<b>F</b> Rear Yard
			Intended Use
<b>G</b> Width of Construction	<b>H</b> Depth of Construction	Area of Construction	Height of Construction
			Stories
Foundation Type	Foundation Style	Heating System	Source of Water
Framing Type	Roof Type	Sewage	Estimated Cost of Work

Description of Project

### SECTION D: DECLARATION AND RESPONSIBILITIES OF THE PERMIT HOLDER

The applicant hereby agrees:

- (a) that this is an application only, no work can commence until a permit is issued.
- (b) that the Permit granted under the terms of this application is automatically cancelled if the applicant fails to conform with any By-laws or Regulations relevant to this application or deviates from the terms of this application.
- (c) neither the issuance of this building permit nor the approval of plans or specifications, shall relieve the owner from full compliance with the Building Code and applicable Provincial Regulations and By-laws.
- (d) that once constructed, the applicant agrees to use the structure for the sole purposes indicated in the preceding application.
- (e) to contact KingsRSC:
  - at least 48 hours notice to the Building Inspector of your intention to start the work authorized by the Permit
  - at least 24 hours notice for a pre-pour inspection of an Insulated Concrete Form (ICF) foundation
  - at least 24 hours notice to the Building Inspector of any backfilling of the excavation
  - at least 24 hours notice for pre-dry wall inspection in a residence
  - Notice of completion of the work described in the Permit to the Building Inspector within 10 days of such completion

I have read and accept the terms above.

Owner's or Authorized Agent's Signature

Date

Building Inspectors Signature

Date

The KingsRSC will not accept responsibility for any damages caused to structures erected in areas subject to flooding, solution collapse or other damages resulting from an act of nature. The personal information collected by KingsRSC may be subject to disclosure under the provisions of the Right to Information and Protection of Privacy Act, S.N.B. 2009, c. R-10.6.



## BUILDING INSPECTION SITE PLAN

TYPE OF JOB

ADDRESS

APPLICANT'S SIGNATURE

REQUIRED DIMENSIONS (On First Page):

WIDTH OF PROPERTY A \_\_\_\_\_  
 DEPTH OF PROPERTY B \_\_\_\_\_  
 FRONT YARD C \_\_\_\_\_  
 REAR YARD D \_\_\_\_\_  
 LEFT SIDE YARD E \_\_\_\_\_  
 RIGHT SIDE YARD F \_\_\_\_\_  
 WIDTH OF HOUSE G \_\_\_\_\_  
 DEPTH OF HOUSE H \_\_\_\_\_

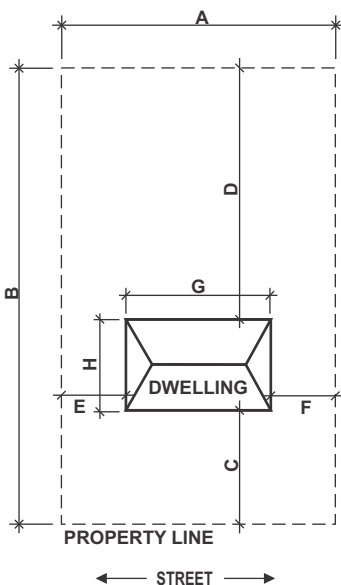

ANY OTHER STREETS LINING THE PROPERTY SHALL BE SHOWN

ALL EXISTING STRUCTURES.

ANY SWALES, WATERCOURSES OR EASEMENTS.

PROPOSED STRUCTURE(S) WITH DIMENSIONS (FENCE, DECK, BALCONY, SHED, ETC)

DIMENSIONS BETWEEN THE PROPOSED STRUCTURE AND THE SURROUNDING PROPERTY LINES

IF A DETACHED STRUCTURE IS PROPOSED, THE DIMENSION BETWEEN THE STRUCTURE AND THE MAIN DWELLING SHALL BE SHOWN.

REQUIRED DIMENSIONS:

WIDTH OF PROPERTY	A
DEPTH OF PROPERTY	B
FRONT YARD	C
REAR YARD	D
LEFT SIDE YARD	E
RIGHT SIDE YARD	F
WIDTH OF HOUSE	G
DEPTH OF HOUSE	H

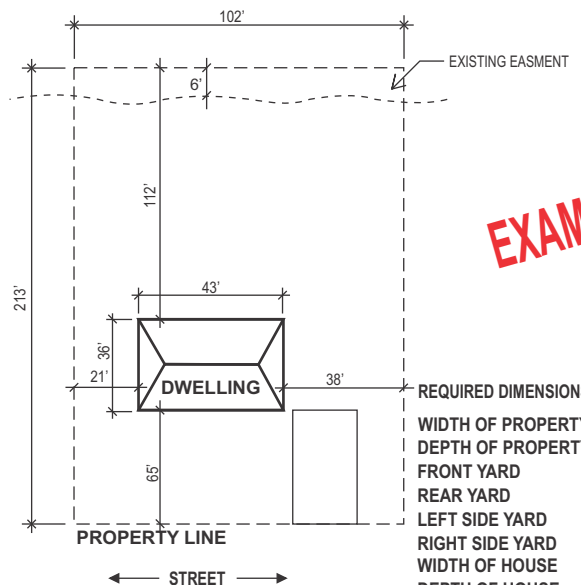

**EXAMPLE**

REQUIRED DIMENSIONS:

WIDTH OF PROPERTY A	102
DEPTH OF PROPERTY B	236
FRONT YARD C	65
REAR YARD D	112
LEFT SIDE YARD E	21
RIGHT SIDE YARD F	38
WIDTH OF HOUSE G	43
DEPTH OF HOUSE H	36